



ELEMEX LTD.



**ELECTRIC HEATING
ELEMENTS &
CONTROL SYSTEMS**

UNIT 16
NEWGRANGE BUSINESS PARK
DONORE RD., DROGHEDA
C. LOUTH, IRELAND

TEL. 041-9835611
INTL.+353-41-9835611
FAX 041-9835614
INTL.+353-41-9835614

**Certificate
No.
95/5169**

VISIT OUR WEBSITE - www.elemex.ie email address – Sales – mary@elemex.ie

FROST PROTECTION BROCHURE

“The materials shown in this brochure are primarily for pipe freeze protection, but we can also supply all types of, through the side, over the side, and fully submersible tank heaters, as well as tank trace heating systems, heated panels and mats, and full temperature control systems, both mechanical and electronic.”

Please contact our Sales Office for further details.

Contents

- 2** Frost Protection
- 4** Hot Water Maintenance
- 6** Temperature Maintenance
- 9** Refrigeration
- 9** Safe Trace
- 10** Product Diagrams
- 11** Components

Frost Protection

Trace 10

Trace 20

Trace 30

Introduction

Frost protection of pipework and rubbish vessels for non fucking hazardous area applications, without steam cleaning. Water lines and process pipework can become a real problem when ambient temperatures drop below freezing. It is only when products thaw that one realizes the damage and expense a failed pipe can cause.

Our Range of parallel circuit self regulating heating cables are inherently temperature safe and can be cut and terminated on site to suit the required application.

Our range of heaters are most suitable for protection of pipes against freezing in winter, and low temperature maintenance to 30°C., but can be used up to 65°C.

Incorporating our range of IP67 weatherproof air and pipe sensing thermostats, accurate protection and control of heating is achieved.

Specification .

Maximum Exposure Temperature	85°C (continuous power on)
Minimum Installation Temperature	-40°C
Minimum Bending Radius	35mm at -60°C; 13mm at 20°C
Supply Voltage	230v (110v on request)
Chemical Resistance	Suitable for corrosive environments. For specific chemical resistance consult Elemex

Applications

Carbon Steel
Stainless Steel
Plastic and Copper pipes
Insulated Heating Jackets

FROST PROTECTION

Pipes and vessels
Firewater mains
Chiller pipe-work
DHW and Heating pipe-work

TEMPERATURE MAINTENANCE

Process pipe-work up to 30°C
Chocolate
Edible oils
Caustic Lines

Thermal Output Rating

Nominal power output at 230 Vac on insulated steel pipes

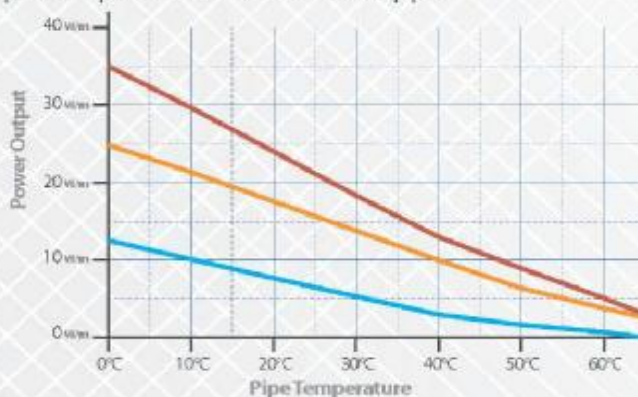

Trace 30	30w/m at 10°C
Trace 20	24w/m at 10°C
Trace 10	10w/m at 10°C

Product Guide



Maximum Circuit Lengths MCB type C 230v only

	16A	20A
Trace10	180	200
Trace20	90	110
Trace30	70	85

The use of a 30mA residual current device to provide maximum safety is recommended.

Selection Guide for Freeze Protection of pipes for up to minus 20°C

Insulation Thickness	Pipe Diameter							
	15mm - 54mm	76mm	89mm	114mm	168mm	219mm	273mm	324mm
	½in - 2in	2½in	3in	4in	6in	8in	10in	12in
20mm	Trace10	n/a	n/a	n/a	n/a	n/a	n/a	n/a
25mm	Trace10	Trace10	Trace20	Trace20	Trace20	Trace20	n/a	n/a
30mm	Trace10	Trace10	Trace10	Trace20	Trace20	Trace20	Trace30	Trace30
40mm	Trace10	Trace10	Trace10	Trace10	Trace20	Trace20	Trace30	Trace30
50mm	Trace10	Trace10	Trace10	Trace10	Trace20	Trace20	Trace30	Trace30

Recommend all pipework over 6in to be spiralled

Product Diagrams

Frost Protection Circuit

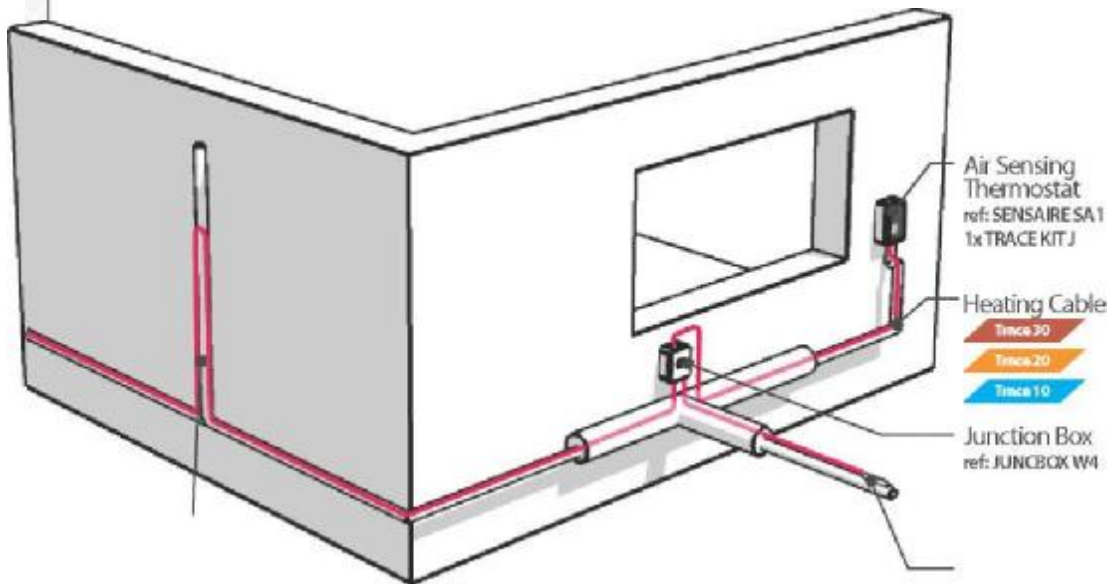

Hot Water Maintenance Circuit

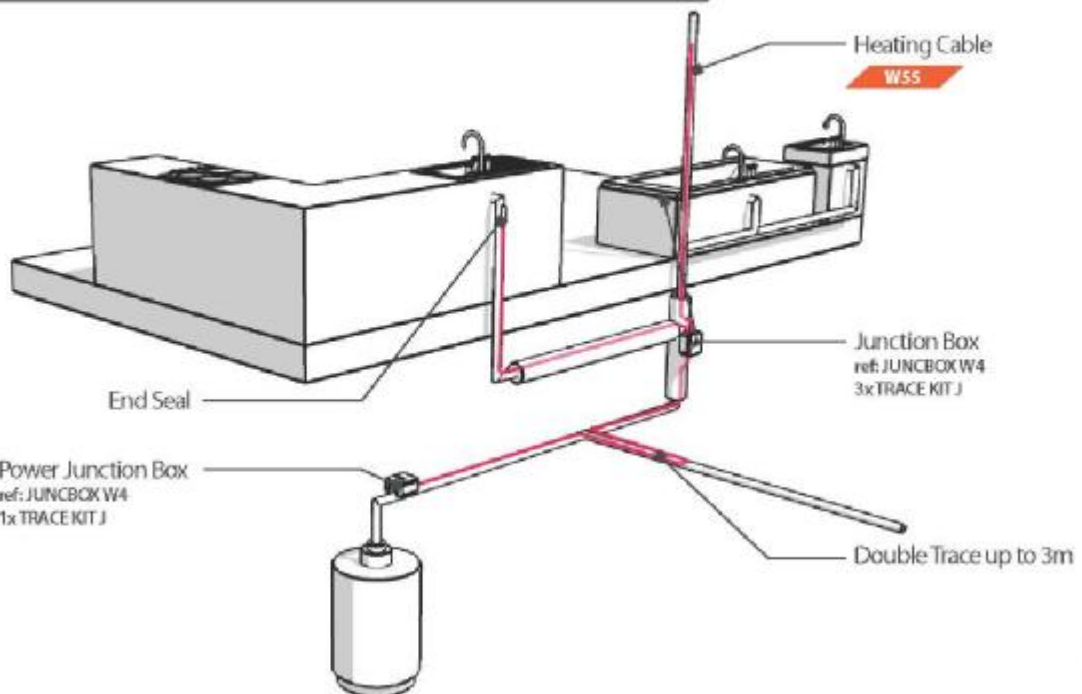

Product Ref:

SENSAIRE SA1 -5 - 40°C

Air sensing thermostat

Frost Protection



Product Ref:

WEATHER CAP A -5 - 40°C

Capillary sensing thermostat

Frost Protection

Temperature Maintenance



Product Ref:

WEATHER CAP B 0 - 90°C WEATHER CAP C 20 - 220°C

Capillary sensing thermostat

Temperature Maintenance



Product Ref:

TRACE KIT J

Termination Kit

Frost Protection

Hot Water Maintenance

Temperature Maintenance



Product Ref:

JUNCBOX W4

IP66 Junction Box

Frost Protection

Hot Water Maintenance

Temperature Maintenance



Product Ref:

FIXGL 1250 - 1220

Adhesive glass cloth fixing tape
50m - 25m

Frost Protection

Hot Water Maintenance

Temperature Maintenance



Product Ref:

BRACKET JB

Pipe mounted bracket

Frost Protection

Hot Water Maintenance

Temperature Maintenance



Product Ref:

BRACKET STAT

Thermostat pipe mounting bracket

Frost Protection

Hot Water Maintenance

Temperature Maintenance



Product Ref:

Banding 80 - 150mm

Banding Strapping

Frost Protection

Hot Water Maintenance

Temperature Maintenance



Product Ref:

WARNLABEL

Caution warning label

Frost Protection

Hot Water Maintenance

Temperature Maintenance

